

STANDARD FLUSH MOUNT FRAME (SINGLE POST)

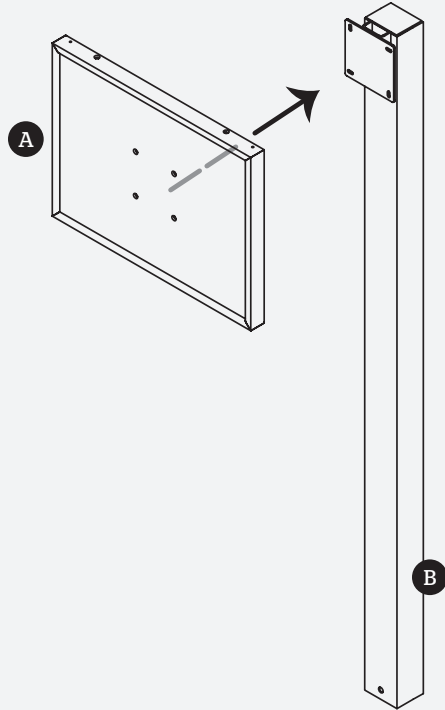

Fig. 1

TOOLS REQUIRED

- 5/32" Allen driver
- 7/16" socket or wrench

PARTS INCLUDED

- A** Sign frame with removable top rail (x1)
- B** Post with welded 6"x6" plate (x1)
- C** 1/4"x20 flat head screws (x4)

ASSEMBLY DIRECTIONS

1. Unpack all parts and inspect for damaged or missing items.
2. Arrange all items for assembly using corrugated packaging to protect items from damage.
3. Verify that removable rail is in top position.
4. Attach the frame to the post plate using the provided hardware (**C**) and a 5/32" allen driver and 7/16" socket or wrench.

IN GROUND INSTALLATION

TOOLS REQUIRED

- 5/32" Allen driver
- 7/16" socket
- Post hole digger
- Shovel
- Hammer
- Level
- Tape Measure
- Tamping stick for gravel
- Kraft paper or plastic sheet
- Wood braces and clamps

MATERIALS NEEDED

- Concrete and/or class 5 gravel 6-8" length of rebar (if desired)

ASSEMBLY DIRECTIONS

1. Insert rebar through hole on post end (if desired) to form "T". Dig 8"-10" diameter hole to a depth of about 6" below the frost line. Add several inches of tamped gravel to serve as footing base. Verify installation height—bottom of frame should mount 28'-32" from grade. For a 24"H frame, a mount height of 30" from grade allows for about 20" post burial. For a 18"H frame, a 30" mount height from grade allows for about 22" post burial.
2. Protect post with wrapped kraft paper or plastic sheet. Verify level, plumb and installation height. Stabilize post in hole with wood braces and camps. Backfill with additional tamped class 5 and/or prepared concrete.
3. After concrete has set (if used), remove braces and plastic sheeting. Backfill as desired.
4. Remove braces and plastic sheeting, if used

Fig. 2

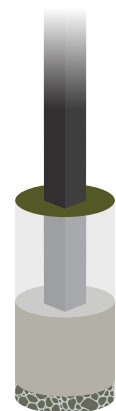

Footing specifications should be based on soil conditions and frost depths in your geographic area.