

UPRIGHT FRAMELESS PEDESTAL ASSEMBLY AND IN GROUND INSTALLATION

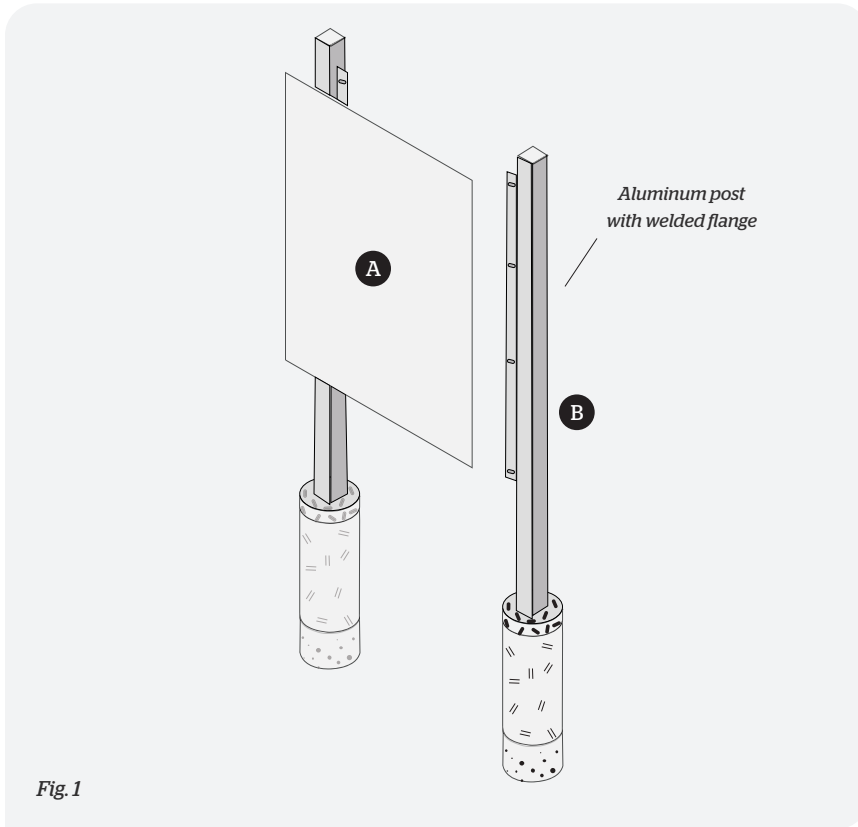

PARTS

- A Sign (x1)
- B Sign posts with welded flange (x2)

TOOLS REQUIRED

- 5/32" Allen driver
- Post hole digger
- Shovel
- Level
- Tape Measure
- Tamping stick for gravel
- Kraft paper or plastic sheet
- Wood braces and clamps

MATERIALS NEEDED

- Concrete and/or class 5 gravel
- 6-8" length of rebar (if desired)

ASSEMBLY DIRECTIONS

1. Unpack all parts and inspect for damaged or missing items.
2. Arrange all items for assembly using corrugated packaging to protect items from damage.
3. With two people, attach the sign panel to the flange welded to the post using hardware provided with the high pressure laminate sign. DO NOT OVERTIGHTEN.
4. Insert rebar through hole on post ends (if desired) to form a "T". Dig 8"-10" diameter holes 6" below the frostline, spaced 4"-5" wider than the width of the sign.
5. Add several inches of tamped gravel to serve as footing base. Verify installation height—bottom of sign should mount 28'-32" from grade.
6. Wrap posts with kraft paper or plastic sheet to protect from concrete spatter. Stabilize posts in holes with wood braces and clamps. Backfill with additional tamped class 5 and/or prepared concrete.
7. After concrete has set (if used), remove braces and plastic sheeting, if used.

Fig. 2



Footing specifications should be based on soil conditions and frost depths in your geographic area.